

IMPROVING

A01

RESOURCE

Revision questions – Unit 1

Ions

1. What is an element?
2. What is a molecule?
3. What is a compound?
4. What is an ion?
5. What does inorganic mean?
6. Which ion is a necessary component of chlorophyll?
7. Which ion is a component of haemoglobin?
8. What is the role of calcium ions in plants?
9. What is the role of calcium ions in animals?
10. Name two types of molecule that contain phosphate.

Water

1. What does “water is a polar molecule” mean?
2. What type of bonds hold different water molecules together?
3. What does “high specific heat capacity” mean?
4. What is the significance of water having a high specific heat capacity?
5. What does high latent heat of vaporisation mean?
6. What is the significance of this property to mammals?
7. What does water provide for aquatic animals?
8. Which processes is water a reactant in?
9. Which processes is water a product from?
10. Define condensation and hydrolysis.

Carbohydrates - monosaccharides

1. What do the terms: monomer, dimer and polymer mean?
2. What is the difference between a structural and a molecular formula?
3. What is an isomer?
4. What is the general term for a single sugar unit?
5. How many carbons do the following sugars have: triose, pentose, hexose?
6. What is the general formula for a monosaccharide?
7. Name: a triose, two pentose and three hexose sugars.
8. Name two molecules that contain ribose and one that contains deoxyribose.
9. What is the function of triose and hexose sugars?
10. Why are glucose, galactose and fructose described as isomers of each other?

Carbohydrates – disaccharides

1. Describe the difference between alpha and beta glucose.
2. Which two monomers make up: sucrose, maltose, lactose?
3. What is the function of sucrose?
4. Describe the reaction that is involved in joining two monosaccharides.
5. What is the precise term for the bond that links two glucose molecules together in maltose?
6. Describe how you would test for the presence of a reducing sugar?
7. Why is this test termed semi-quantitative?
8. Describe what you would do to test for a non-reducing sugar.
9. What is the general formula for a disaccharide?
10. Where is lactose found?

Carbohydrates – polysaccharides

1. Starch consists of two polymers, what are their names?
2. Which isomer of glucose is the monomer of starch?
3. What makes starch useful as a storage compound of glucose?
4. Where is glycogen stored?
5. What is the significance of the highly branched nature of glycogen?
6. Which isomer of glucose is the monomer of cellulose?
7. What properties of cellulose make it suitable for the cell wall of plants?
8. What are the similarities and differences between chitin and cellulose?
9. Where would you find chitin?
10. Describe the test for starch.

Lipids

1. What are the constituent molecules in a lipid/triglyceride?
2. What are the differences between a triglyceride and a phospholipid?
3. Distinguish between a saturated and unsaturated fatty acid.
4. List the functions of lipids.
5. Give two reasons that lipids are a good energy store.
6. What is the general formula for a saturated fatty acid?
7. Why is consumption of too many saturated fats considered unhealthy?
8. Which part of a phospholipid is hydrophilic and which is hydrophobic?
9. What is the bond called between a fatty acid and glycerol?
10. Describe the test for a lipid.

Proteins

1. What is the monomer of a protein?
2. What is the bond called between two amino acids?
3. What is the formula of the carboxylic acid group of an amino acid?
4. What is the formula of the amino group of an amino acid?
5. What property does the amino group have?
6. State what is meant by the R group of an amino acid.
7. The carboxylic acid, amino and R groups are all bonded to a central carbon. What other atom is bonded to the central carbon?
8. How many naturally occurring amino acid types are there?
9. Describe the test for a protein.

Protein structure

1. Define the primary structure of a protein.
2. What bonds hold the shape of an alpha helix or beta pleated sheet?
3. What level of structure do alpha helices and beta pleated sheets have?
4. Name two secondary structure proteins.
5. How are secondary structure proteins termed that relates to their function?
6. Name the four types of bond that can form between R groups in a tertiary structure protein?
7. Give an example of a tertiary structure protein.
8. The 3D shape of a tertiary structure protein is critical for its function. What term is applied to tertiary structure proteins?
9. What is a quaternary structure protein?
10. Name one quaternary structure protein and give its function.

Cell organelles

1. What is a cell organelle?
2. What is the purpose of membranes within the cell?
3. Why might it be correct to state that the cell wall is not an organelle?
4. Which is the largest cell organelle?
5. What is chromatin made of?
6. What is the function of the nuclear pores?
7. What does the nucleolus manufacture?
8. State two functions of DNA.
9. What is the term applied to the two membranes surrounding the nucleus?
10. What is the function of the nuclear envelope?

Double membraned organelles

1. What is the function of mitochondria?
2. What is the significance of the cristae?
3. What is the fluid in the centre of a mitochondrion called?
4. What is the space between the inner and outer membrane of a mitochondrion called?
5. What are the membranes within a chloroplast called?
6. What is a stack of thylakoids called?
7. What is the fluid surrounding the thylakoids called?
8. What is stored within chloroplasts?
9. What is the function of the circular DNA within chloroplasts and mitochondria?
10. What type of ribosomes are present in chloroplasts and mitochondria?

Single membraned organelles

1. What is the difference in structure between rough and smooth endoplasmic reticulum?
2. What is the difference in function between rough and smooth endoplasmic reticulum?
3. State two functions of the Golgi Body.
4. Within which structures do proteins travel from the rough endoplasmic reticulum to the Golgi Body?
5. What do lysosomes contain?
6. What is the difference between the vacuoles in plant and animal cells?
7. What is the membrane called that surrounds the vacuole in plant cells?
8. What is the function of the vacuole in a plant cell?

Non-membranous organelles

1. What size are the ribosomes in plant and animal cells?
2. What is the function of a ribosome?
3. Which type of cells contain centrioles?
4. Describe centrioles.
5. What is the function of centrioles?
6. Which type of cells have a cellulose cell wall?
7. How does the structure of cellulose make it suitable for a cell wall?
8. Describe the permeability of the cell wall.
9. What is the term for the gaps in the cell wall that connect plant cells together?

Eukaryotic and Prokaryotic cells and Viruses

1. What does cell theory state?
2. What is the main difference between a eukaryotic and prokaryotic cell?
3. What is the difference in ribosomes between a eukaryotic and prokaryotic cell?
4. Give two ways in which the DNA in eukaryotes and prokaryotes differs?
5. Where does respiration take place in prokaryotes?
6. What is the cell wall made of in prokaryotes?
7. Describe the structure of a virus.
8. What does lytic cycle mean?

Tissues, Organs and Systems

1. Define the term "tissue".
2. What is the difference between a tissue and an organ.
3. Why is an artery an organ but a capillary a tissue?
4. Where would you find squamous epithelial tissue and how is its shape important?
5. What does a goblet cell make and which organelles would you expect to be abundant in one?
6. Where would you find ciliated epithelial tissue, what do the cilia do?
7. What is the difference between striated and smooth muscle?
8. What is the difference between striated and cardiac muscle?
9. What is the function of the collagen fibres in connective tissue?
10. What is a system?

Membrane structure

1. Why is the accepted model of membrane structure termed "fluid-mosaic"?
2. What do the terms hydrophilic and hydrophobic mean?
3. Explain why phospholipids form a bilayer.
4. What is an intrinsic protein?
5. What is a channel protein?
6. What is an extrinsic protein?
7. What determines the position of a protein in the membrane?
8. What is a glycolipid?
9. What is a glycoprotein?
10. What is the collective name for glycolipids and glycoproteins on the outer surface of a membrane?

Diffusion

1. Define "diffusion".
2. What feature of the phospholipid bilayer prevents polar and charge particles crossing a membrane?
3. Name two gases and two vitamins that can cross the membrane by simple diffusion.
4. Explain how lipid solubility and the size of the molecule affect the rate of diffusion.
5. Explain how the surface area of a cell membrane affects the rate of diffusion.
6. What adaptation of the cell membrane increases surface area?
7. How does diffusion path affect the rate of diffusion?
8. How does concentration gradient affect the rate of diffusion?
9. Explain how temperature affects the rate of diffusion.
10. Give a BRIEF (no more than 5 bullet points) account of the investigation into the effect of temperature on permeability of beetroot membranes.
11. Sketch a graph of the investigation results and explain them.
12. State two differences and two similarities between simple and facilitated diffusion.
13. Give the names of two substances that could be transported by facilitated diffusion.
14. What is co-transport? Give an example.

Osmosis

1. Define osmosis in terms of water potential.
2. If a solution has a lower water potential than another is it hypertonic or hypotonic?
3. What does the term isotonic mean?
4. What does “no net movement of water” mean?
5. What happens if a red blood cell is placed in a hypertonic solution?
6. What happens if a red blood cell is placed in a hypotonic solution?
7. What does osmotic lysis mean and why does it not occur in plants cells?
8. What is pressure potential?
9. Give the equation that represents water relations in plants. Use the symbols: Ψ_w , Ψ_s and Ψ_p .
10. Draw a plasmolysed cell, label the cell wall, cell membrane and cytoplasm.
11. Give a BRIEF (no more than 5 bullet points) account of how water potential of potato tissue can be determined by the mass method.
12. Give a BRIEF (no more than 5 bullet points) account of the plasmolysis method of determining solute potential in red onion cells.

Active Transport Methods

1. What does the term “active” mean when referring to membrane transport?
2. What are the features of active transport across the cell membrane?
3. What effect does cyanide have on active transport?
4. Why is active transport affected by oxygen concentration?
5. Why is the rate of active transport and facilitated diffusion limited?
6. What are the two methods of bulk transport into the cell?
7. What is the term for release of substances from vesicles by the vesicle membrane fusing with the cell membrane?
8. What is the term that describes a cell engulfing a particle to enclose it in a vesicle within the cell?
9. What effect does exocytosis have on the surface area of a cell membrane?
10. What effect does endocytosis have on the surface area of a cell membrane?

Enzymes

1. What is a catabolic reaction?
2. What is an anabolic reaction?
3. What is a catalyst?
4. What are biological polymer are enzymes made of?
5. What is the difference between an intracellular and extracellular enzyme?
6. Describe the lock and key theory of enzyme action.
7. Describe what is meant by induced fit
8. Give an example of an enzyme that works by induced fit.
9. Explain how the active site makes enzymes specific to their substrate.
10. What is the name of the energy lowered by enzymes that increases the rate of reactions.

Factors affecting rate of enzyme controlled reactions

1. Explain how increasing temperature increases the rate of reaction up to the optimum.
2. What is meant by optimum?
3. Explain how increasing temperature above the optimum decreases the rate of reaction.
4. What is meant by denaturation?
5. Describe the effect of small changes in pH away from the optimum.
6. Describe the effect of large changes in pH away from the optimum.
7. Describe the difference between competitive and non-competitive inhibition.
8. Sketch a graph to show the effects of increasing substrate concentration on: the rate of an enzyme controlled reaction; the rate of reaction affected by a competitive inhibitor; the rate of reaction affected by a non-competitive inhibitor.
9. Explain the difference between the graphs for non-competitive and competitive inhibitors.
10. List two advantages of using immobilised enzymes in industry.
11. What are the advantages of biosensors?
12. Give an example of a biosensor.

ATP

1. Draw simple labelled diagram to show the structure of a nucleotide.
2. What are the components of ATP?
3. What is the difference between endergonic and exergonic reaction?
4. How much energy is released from one mole of ATP when it is hydrolysed to ADP and P_i ?
5. What does “universal energy currency” mean?
6. List 3 advantages of using ATP to provide energy in cells.
7. What is the sugar in DNA?
8. Which bases are in the nucleotides of DNA?
9. What is the sugar in RNA?
10. What are the bases in RNA?
11. How does the structure of ATP differ from that of DNA?
12. How does the structure of ATP differ from that of RNA?

DNA and RNA

1. What does DNA stand for?
2. What does RNA stand for?
3. What are the two functions of DNA?
4. What are the three types of RNA?
5. Which is longer, DNA or RNA.
6. Which bases are pyrimidines and which are purines?
7. Which are the complementary base pairs in DNA and RNA?
8. Complementary bases are linked by bonds, what type of bonds are these?
9. What does antiparallel mean?
10. What is the shape of DNA?

DNA Replication

1. Why does DNA replication need to happen?
2. During which part of the cell cycle does DNA replication take place?
3. What is the accepted model of DNA replication called?
4. What does semi-conservative replication mean?
5. What is the enzyme that catalyses DNA replication?
6. Which two scientists undertook the experiment that showed how DNA replication happens?
7. Which part of the DNA molecule was labelled in the experiment?
8. What were they labelled with?
9. Draw the results for generation 0, 1 and 2 labelling the lines on the tubes.
10. How do these results show that conservative and dispersive replication do not happen?
11. What are the main steps in DNA replication?
12. What does DNA polymerase do?

Protein Synthesis

1. What does the base sequence in DNA code for?
2. How many bases code for each amino acid?
3. What is the process called by which the code is copied from DNA to mRNA?
4. What is the relationship between DNA and mRNA?
5. Which enzyme controls transcription?
6. What is an exon and what is an intron?
7. What is meant by post-transcriptional modification?
8. Where are proteins synthesised?
9. How does mRNA leave the nucleus?
10. Write down two structural differences between DNA and RNA.
11. What is amino acid activation?
12. What determines which amino acid is attached to a molecule of tRNA?
13. What is an anticodon?
14. What is the relationship between the bases on a codon and anticodon?
15. How many codons can a ribosome accommodate at one time?
16. How are codons and anticodons joined on the ribosome?
17. Describe how the DNA base sequence determines the amino acid sequence in the primary structure of a protein.
18. What type of bond links two amino acids together?
19. What type of codon terminates the synthesis of a protein?
20. What is meant by post-translational modification?

Mitosis

1. Explain what is meant by diploid and haploid.
2. What does homologous mean?
3. Describe what happens in interphase; prophase; metaphase, anaphase and telophase.
4. Why is interphase not counted as part of mitosis?
5. What is cytokinesis?
6. Explain why the DNA content of a cell doubles in interphase and halves in cytokinesis.
7. Describe the products of cytokinesis after a mitotic division.
8. What is the significance of mitosis?
9. What is the cause of cancer?
10. What is the stain used in a root tip squash?
11. Why is a stain necessary?
12. Why is the root tip used to observe mitosis and not the shoot tip?
13. What is the purpose of the acid?
14. Why is the slide 'squashed'?
15. What is the formula to calculate mitotic index?
16. What does the mitotic index value indicate?
17. How would you calculate the length of time taken to undergo each stage of mitosis using the root tip squash method?

Meiosis

1. What is meiosis for?
2. What is the significance of haploid gametes?
3. How many divisions are there in meiosis?
4. What is the sequence of the stages?
5. What two processes in meiosis lead to genetic variation?
6. Why is variation important?
7. Write down 3 events that happen in interphase.
8. Describe 3 things that happen in prophase I.
9. What is the effect of crossing-over on the genetic makeup of the chromatids?
10. What attach to the spindles in metaphase I?
11. What event in metaphase I leads to genetic variation in the gametes?
12. Describe Anaphase I.
13. What is inside a polar body?
14. Draw a diagram to show metaphase II in a cell that at interphase had a diploid number of $2n = 6$.
15. Draw a labelled diagram of a cross section of an anther.
16. How could you distinguish between cells about to divide; those that have undergone meiosis I and those that have undergone meiosis II.
17. How would you know if a cell was in metaphase?
18. How would you know if a cell was in anaphase?

Unit 2 Revision Questions

Classification

1. What does hierarchical mean in classification?
2. What is the hierarchy of taxons from largest to smallest?
3. What does phylogenetic mean?
4. Why is classification described as “tentative”?
5. What are the three domains?
6. Which two of the domains contain prokaryotic cells?
7. What feature of cells has been used to establish the relatedness of organisms into their domains?
8. What is an extremophile?
9. Which of the 5 kingdoms have eukaryotic cells?
10. What are the features of eukaryotes that distinguish them from prokaryotes?
11. List 3 distinguishing features of each of the 5 kingdoms.
12. Why are biochemical methods of assessing relatedness superior to using morphological features?
13. List two biochemical methods of establishing relatedness.
14. Why are DNA base sequencing methods a better biochemical method than amino acid sequencing?
15. Define homologous and analogous and give an example of each.
16. Define a species.
17. What does binomial naming mean?
18. What taxons do the first and second names represent?
19. Where are the common ancestors located on a phylogenetic tree?
20. How could you use a phylogenetic tree to organise most closely to least closely related?

Biodiversity

1. Define biodiversity.
2. How does biodiversity vary between the two poles of the earth?
3. What does “biodiversity varies temporally” mean?
4. List the factors that can cause variation in biodiversity.
5. What calculation is performed to assess biodiversity in a habitat?
6. What are the two things that must be counted to do this calculation?
7. Write out the formula defining any letters used.
8. What two number form the lower and upper limits of the calculation?
9. How could you tell from the calculation that an area was more diverse than another?
10. Describe how you would sample two areas to get representative data.
11. What is polymorphism?
12. How could you recognise genetic polymorphism in a species?
13. How would you assess genetic diversity in a species?
14. How can biodiversity be determined at a molecular level?
15. What feature would inform you that a species was genetically diverse?
16. How has biodiversity on the planet been generated?
17. Give examples of organisms that are anatomically, behaviourally and physiologically adapted to extreme environments like deserts and the arctic.

Gas exchange

1. What are the conditions for gas exchange surfaces?
2. What is the total oxygen requirement of an organism proportional to?
3. What is the rate of oxygen absorption proportional to in an organism?
4. What happens to the surface area to volume ratio of an organism as size increases?
5. In small and unicellular organisms where does gas exchange take place?
6. What is the gas exchange surface of an *Amoeba*?
7. Describe the surface area to volume ratio of an *Amoeba*.
8. Describe the diffusion path of an *Amoeba*?
9. What is the gas exchange surface of a flatworm?
10. How does the flattened shape of a flatworm aid gas exchange?
11. What is the gas exchange surface of an earthworm?
12. Explain how the shape of the earthworm aids gas exchange.
13. Other than shape explain one other feature of earthworms that aids oxygen absorption.
14. Amphibia have aquatic tadpoles, what is the gas exchange surface of a tadpole?
15. Adult amphibia have two gas exchange surfaces, what are they?

Fish

1. What is the gas exchange surface in a fish?
2. What is the function of gill rakers?
3. How does the gas exchange surface of a fish fulfil the general requirements of a gas exchange surface?
4. How do fish maintain a concentration gradient of oxygen across their gill surface?
5. Describe the movements that result in water entering the fish.
6. Describe the movements that result in water passing over the gills and exiting the fish.
7. What is meant by "counter-current flow" and "parallel flow".
8. Explain why counter-current flow is more efficient at absorbing oxygen into the blood.
9. Sketch graphs to illustrate counter-current and parallel flow, label the lines and add arrows to show the direction of movement of the blood and water.
10. Predict the gas exchange features of an active fast swimming fish.

Humans

1. Draw and label a diagram of the human lungs and associated structures.
2. Explain the significance of the cartilage being C-shaped in the trachea.
3. What is the gas exchange surface in humans?
4. Give an advantage to a terrestrial organism of internal lungs.
5. How do the features of the gas exchange surface in humans fulfil the general features of gas exchange surfaces?
6. What is the role of surfactant?
7. How is a concentration gradient maintained at the gas exchange surface?
8. What happens when the intercostal muscles contract?
9. What happens when the diaphragm contracts?
10. Describe the role of the pleural membranes in negative pressure breathing.

Insects

1. Why do insects have an impermeable cuticle?
2. What is the function of the spiracles in insects?
3. What is the advantage to an insect of being able to open and close the spiracles?
4. What is the gas exchange surface in an insect?
5. Describe the ventilation movements of an insect.

Plants

1. Draw and label a diagram of a TS of a typical leaf.
2. Why is the upper epidermis transparent?
3. Which is the main photosynthetic tissue of a leaf?
4. How does water enter a leaf?
5. Which tissue removes photosynthetic products from a leaf?
6. What is the function of an open stomata?
7. What is the significance of the air spaces in spongy mesophyll?
8. What is the advantage to a plant of closing stomata at night?
9. Draw a pair of guard cells showing the relative thickness of the cell wall.
10. Describe the mechanism of stomatal opening.
11. Give a BRIEF (no more than 5 bullet points) account of how stomatal density can be investigated.

Circulatory systems

1. What is a closed circulatory system?
2. What is an open circulatory system?
3. Why do insects not carry respiratory gases in their blood?
4. What is single circulation?
5. State one disadvantage of single circulation.
6. Name a type of organism that has single circulation.
7. What is a double circulatory system?
8. What are the advantages of a double circulatory system?
9. What is meant by pulmonary circulation?
10. What is meant by systemic circulation?

Human circulatory system

1. Which organ provides the pressure to move blood around the body?
2. Which type of blood vessels carry blood away from the heart?
3. Why do arteries have thick walls?
4. Why do arteries have thick elastic tissue?
5. What is the function of the smooth muscle in an artery wall?
6. Why are capillaries a tissue rather than an organ?
7. State two functions of capillaries.
8. How are capillaries adapted for gas exchange?
9. Which type of blood vessels carry blood back to the heart.
10. Describe the role of skeletal muscle in returning blood to the heart.
11. What internal feature of veins ensures unidirectional flow of blood.
12. Arterioles have more muscle than elastic tissue, what is the significance of this?

The Heart

1. Draw a diagram of the heart and label all the blood vessels, valves, the septum and the apex.
2. Describe the route that blood takes through the heart from both veins to both arteries.
3. Why is heart muscle described as myogenic?
4. Draw a normal ECG trace and label it.
5. What happens during the P wave?
6. What happens during the QRS complex?
7. What does the T wave represent?
8. How could you use an ECG trace to calculate heart rate?
9. Where does the heart beat initiate?
10. What is the significance of the AVN (Atrio-Ventricular Node)?
11. Why is it important the wave of excitation passes down the Bundle of His?
12. What do the Purkinje fibres do?
13. Sketch a graph of the pressure changes around the circulatory system.
14. Why does the pressure in the aorta not drop to 0?

Cardiac Cycle

1. What happens when the SAN sends out a wave of excitation?
2. What happens to the pressure in the atria when they contract?
3. Where does the blood move to when the atria contract?
4. Which valves are open when the atria contract?
5. What happens to the pressure in the ventricles when they contract?
6. What happens when the pressure in the ventricles is higher than that in the atria?
7. Which valves open when the pressure in the ventricles is higher than that in the arteries leaving the heart?
8. What happens to the pressure in the ventricles when they relax?
9. What happens when the pressure in the ventricles drops below that in the arteries?
10. What happens when the pressure in the ventricles drops below that in the atria?

Carriage of carbon dioxide

1. Which cells in blood transport oxygen from the lungs to the tissues?
2. Write an equation which shows how haemoglobin takes up and releases oxygen.
3. List 3 ways in which carbon dioxide is carried in the blood.
4. What reaction does carbonic anhydrase catalyse?
5. What are the products when carbonic acid dissociates?
6. What happens to hydrogen carbonate ions formed in red blood cells?
7. What is the chloride shift?
8. Why does the chloride shift take place?
9. When protons attach to oxyhaemoglobin what happens to the oxygen?
10. What is the Bohr effect?

Oxygen dissociation curves

1. Sketch an oxygen dissociation curve, label the axes.
2. The theoretical model is a straight line. What is the advantage of the sigmoid curve?
3. What is the significance of the range of values at which haemoglobin is fully loaded?
4. What is the significance of the steepest area of the curve.
5. What is the reason for the sigmoid shape of the curve?
6. What is the significance of the curve for foetal haemoglobin being to the left of the adult haemoglobin curve?
7. Name two organisms that have haemoglobin with curves to the left of adult human haemoglobin.
8. Explain the advantage to these organisms of having this type of haemoglobin.
9. Explain one disadvantage of having a curve to the left.
10. Explain the advantage of the Bohr shift.

Plant transport

1. Draw a diagram of a dicotyledon root ts and label it.
2. Draw a diagram of a dicotyledon stem ts and label it.
3. What is the function of a root hair cell?
4. How are mineral ions like nitrate absorbed into root hair cells?
5. Give two adaptations that root hair cells have.
6. Draw two connected cells of the cortex and label the cell wall, cytoplasm, vacuole and plasmodesmata. Draw lines to show the apoplast, symplast and vacuolar pathways.
7. Which of the three pathways use osmosis?
8. Where is the Casparian strip located and what is it made of?
9. Which pathway is blocked by the Casparian strip?
10. What is the significance of the Casparian strip in mineral transport?

Cohesion-tension

1. Describe the adaptations that xylem vessels have for transporting water.
2. Through which structures on the lower epidermis does water vapour leave the leaf?
3. Which two processes are involved in water leaving leaf cells into the air spaces and out of the leaf.
4. As water vapour leaves the leaf cells it is replaced from which structure by osmosis?
5. What is the word that describes the pulling force on the column of water?
6. What is cohesion?
7. What is adhesion?
8. Mineral ions are transported into the xylem in the root, what effect does this have on the water potential of the xylem?
9. Osmosis into the xylem generates a pressure, what is the name of this pressure?
10. Xylem vessels are very narrow and take up water by which phenomenon as a result?
11. Describe the effect of increasing temperature on the rate of transpiration?
12. Describe the effect of increasing humidity on the rate of transpiration?
13. Explain how air movements increase the rate of transpiration.
14. Explain how light intensity affects the rate of transpiration.
15. What is the advantage to a plant of closing stomata at night.

Adaptations

1. What is the term for plants that live in ponds and lakes and have leaves that float on water?
2. Explain why the stomata of such plants are located in the upper epidermis.
3. What are the functions of aerenchyma tissue?
4. What is the term for plants that are adapted to inhabit arid environments?
5. Explain how trichomes reduce water loss.
6. Explain how sunken stomata reduce water loss.
7. Many plants have leaves reduced to needles or spines, how does this reduce water loss?
8. Marram grass has rolled leaves with the stomata facing inwards, how does this reduce water loss?
9. What is the term for plants adapted to live in areas with a medium water availability?
10. How do these plants avoid water loss in unfavourable conditions, eg. winter?

Transport of organic compounds

1. What is the name of the tissue that transports sucrose and other organic molecules away from the leaves?
2. Draw a sieve-tube element and companion cell in LS.
3. How are sieve-tube elements adapted for transport?
4. What is the function of the companion cell?
5. What is the term for the movement of substances through the phloem from high to low pressure?
6. What is the name of the theory by which translocation occurs?
7. Describe what is meant by the terms source and sink and give an example of each.
8. Which membrane transport mechanism is used to load sucrose into phloem at the source?
9. What effect does the loading of sucrose have on water potential?
10. How does water enter the phloem at the source and what effect does this have on pressure?
11. Which organisms can be used to sample phloem contents for analysis?
12. Outline the principles of autoradiography.
13. Briefly describe how providing $^{14}\text{CO}_2$ to leaves and sampling aphid exudate could enable a rate of translocation to be calculated.
14. Which aspects of translocation does mass flow not account for?

Modes of nutrition

1. Distinguish between the terms autotrophic and heterotrophic.
2. What does holozoic nutrition mean?
3. What does photoautotrophic mean?
4. What are organisms that makes organic compounds from inorganic ones using chemical energy called.
5. How does a saprophytic organism obtain nutrients?
6. Define the term parasite.
7. What five processes occur in holozoic nutrition?
8. Distinguish between the terms egestion and excretion.
9. Describe how an *Amoeba* obtains nutrients.
10. Describe the gut of a *Hydra*.

The Human Gut

1. Draw a labelled diagram to show the layers in the wall of a human gut.
2. What is the main function of the buccal cavity, teeth and tongue?
3. Which enzyme is present in saliva and what reaction does it catalyse?
4. Describe the muscle action that transfers a bolus of food from the buccal cavity to the stomach.
5. The stomach has 3 layers of muscle, circular, longitudinal and oblique; how does this structural feature relate to one of the functions of the stomach.
6. State three functions of hydrochloric acid in the stomach.
7. Explain why pepsin is released from the cells that make it in the form of pepsinogen.
8. Describe the reaction that pepsin catalyses.
9. Describe the ways in which acidic chyme is neutralised in the duodenum.
10. Where is bile manufactured and stored?
11. What is the function of bile in fat digestion?
12. Which enzymes does the pancreas produce and what reactions do they catalyse?
13. Draw a labelled diagram of a villus from the small intestine.
14. Which products of digestion are absorbed into capillaries?
15. What leaves the gut via a lacteal?
16. What is absorbed in the colon?
17. Distinguish between the terms endopeptidase and exopeptidase.
18. What activates trypsinogen?
19. Precisely where are dipeptides and disaccharides digested into their monomers.
20. Describe the absorption of glucose including the role of secondary active transport.

Carnivores and Herbivores

1. What is the key difference between the diets of carnivores and herbivores.
2. Which has the longer gut, herbivore or carnivore?
3. Which area of a non-ruminant herbivore contains mutualistic bacteria.
4. What is the role of the mutualistic bacteria?
5. How many chambers are there in a ruminant stomach?
6. What is "chewing the cud" in ruminants?
7. Which chamber of the ruminant stomach does protein digestion take place in?
8. Which chamber of the ruminant stomach contains mutualistic bacteria?
9. Describe the features of herbivore dentition.
10. Describe the features of carnivore dentition.

Parasites

1. Distinguish between the terms endoparasite and ectoparasite.
2. What is the common name for *Pediculus*?
3. How does *Pediculus* feed?
4. Why does *Pediculus* have claws?
5. Where does *Pediculus* lay eggs?
6. How is *Pediculus* transmitted from host to host?
7. Which type of parasite is *Taenia solium*?
8. What organism is the primary host of *Taenia solium*?
9. What organism is the secondary host of *Taenia solium*?
10. How does infection of the primary host happen?
11. How is a tapeworm adapted to not be dislodged by peristalsis?
12. How is the cuticle of a tapeworm adapted to resist gut secretions like enzymes?
13. Why does a tapeworm lack a mouth?
14. What is the significance of a tapeworm producing a large number of eggs that are egested with faeces?

Unit 3 Revision questions

ATP

1. Draw and label a molecule of ATP and ADP to show the component parts.
2. Write an equation to illustrate the relationship between ADP, Pi and ATP.
3. Why is ATP termed the universal energy currency?
4. Give 3 advantages that ATP has as a source of energy in cells.
5. Where does the energy come from to manufacture ATP?
6. List 3 cell processes that utilise ATP.
7. What is the name of the enzyme that synthesises ATP?
8. What provides energy to ATP synthetase to manufacture ATP?
9. How is the proton gradient generated in chloroplasts and mitochondria?
10. What are the differences between the generation of the proton gradient in chloroplasts and mitochondria?

Photosynthesis

Pigments

1. Which tissue in leaves has the highest concentration of chloroplasts and explain the location of this tissue.
2. What is the advantage of chloroplasts moving around these cells?
3. Chloroplasts are transducers, what does this mean?
4. Name 3 accessory pigments found in chloroplasts.
5. What is the primary pigment in chloroplasts?
6. What is the function of the pigments in chloroplasts?
7. What is the advantage to the plant of having accessory pigments?
8. Where precisely are the photosynthetic pigments found?
9. Where precisely is the primary pigment found?
10. What do the chlorophyll a molecules do when exposed to light?
11. Complete the missing three labels:

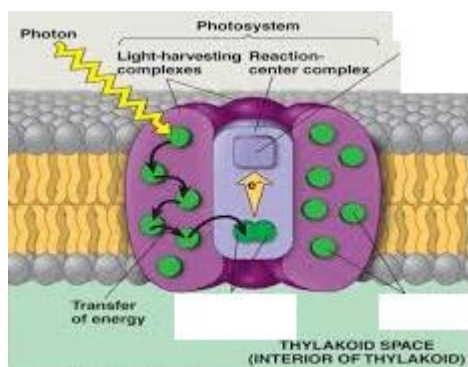

12. Outline a method for separating chloroplast pigments.
13. Sketch a chromatogram to show how an R_f value could be calculated: label the origin and solvent front.
14. What are the similarities and differences between photosystems I and II?

Light dependent reactions

1. Where do the light dependent reactions of photosynthesis take place precisely.
2. What is the energy transformation involved?
3. Sketch a diagram of electron transfer (Z-scheme) label: electron, electron acceptors, NADP, photosystem I, photosystem II
4. Describe the sequence of events starting with light absorption that leads to the formation of NADPH and ATP.
5. What is the name of this process?
6. This reaction is called the "Hill Reaction" and can be investigated by using DCPIP as a hydrogen acceptor. DCPIP is blue when oxidised and colourless when reduced. Outline how you could investigate if light is necessary for the production of reducing power using isolated chloroplasts, include the final colour of the solutions.
7. Why would the solution used to isolate the chloroplasts need to be: ice-cold, isotonic and buffered?
8. What is the name of the process that splits water?
9. Where does this process take place precisely?
10. What is produced from this process?
11. What do each of the products do?
12. Which photosystem is involved in cyclic photophosphorylation?
13. Describe cyclic photophosphorylation, stating the products.
14. Outline how you could use a pond weed such as *Elodea* to assess the rate of photosynthesis?

Light independent reactions

1. Where precisely do the light independent reactions take place?
2. What are the three required reactants for these reactions?
3. Where are these reactants from?
4. What does the enzyme RUBISCO catalyse?
5. What happens to the unstable 6 carbon compound formed?
6. What exactly are the ATP and NADPH used for?
7. Outline the fates of triose phosphate formed.
8. Why are these reactions referred to as a cycle?
9. Outline a method by which immobilised algae and bicarbonate indicator can be used to measure carbon dioxide use in the Calvin Cycle.
10. Some herbicides work by inhibiting the electron transfer chain in the thylakoid membrane; explain how this leads to the death of the plant.

Mineral Nutrition in Plants

1. How are mineral ions taken up by root hair cells.
2. What is the function of nitrate ions for plants?
3. Why are magnesium ions required for plant growth and function?
4. Why are phosphate ions required by plants?
5. Why are sulphate ions required by plants?
6. Outline a method by which the mineral requirements of plants can be investigated.
7. Why is dry mass used to measure growth and not fresh mass?
8. State and explain two variables that should be controlled in the experiment.

Respiration

1. What type of process is respiration?
2. What is the end product of respiration?
3. What is some energy wasted as?
4. What are the high energy bonds that are broken in respiration?
5. What is the key feature of aerobic respiration?
6. Where does aerobic respiration take place?
7. Draw a labelled diagram of a mitochondrion.
8. What types of substrate can be used in respiration?
9. Draw the following molecules: glucose, maltose, an amino acid and a triglyceride.

Chemical reactions in respiration.

1. Where in a cell do the following reactions take place precisely: glycolysis, the link reaction, Krebs's cycle, the electron transport chain, anaerobic respiration.
2. Describe the reactions of glycolysis.
3. What enzymes are involved in glycolysis?
4. List all of the products of glycolysis.
5. Describe the reactions of the link reaction.
6. What enzymes are involved in the link reaction?
7. List the products of the link reaction.
8. Describe the reactions of the Krebs's cycle.
9. What enzymes are involved in the Krebs's cycle?
10. List the products of the Krebs's cycle.
11. What are the sources of the high energy electrons for the electron transport chain?
12. What is the function of the high energy electrons?
13. Where are the protons pumped from and to?
14. What is the enzyme that manufactures ATP using the energy from the proton gradient called?
15. What is the final electron acceptor?
16. What are the products of the electron transport chain?
17. What is the difference in ATP yield when NADH or FADH are used?
18. Describe the reactions of anaerobic respiration (starting with glycolysis) in (a) plants, (b) animals.
19. What end products do fungi and bacteria make when they respire anaerobically?
20. What is the function of NADH in the reactions?
21. For one molecule of glucose:
 - a) Give the numbers of NADH manufactured in glycolysis, link reaction and Krebs's cycle.
 - b) Give the number of FADH manufactured in Krebs's cycle.
 - c) Give the total number of ATP released by substrate level phosphorylation
 - d) Give the total number of ATP released in chemiosmosis.

Energy Budget

1. What is the net gain of ATP in glycolysis?
2. Why is this referred to as a net gain and not just a gain?
3. By what process is this ATP made?
4. How many ATP are made by substrate level phosphorylation in Krebs's cycle?
5. How many ATP are manufactured by chemiosmosis if one NADH enters the electron transport chain?
6. How many ATP can be manufactured per FADH?
7. How many NADH and FADH are made if one molecule of pyruvate enters the reactions in the matrix?
8. Draw a table to show how one molecule of glucose yields 38 ATP.
9. State 2 reasons the maximum yield of 38ATP might not be reached.
10. What yield of ATP is a better estimate per molecule of glucose?
11. What is the yield of ATP from anaerobic respiration of one molecule of glucose?

Other respiratory substrates

1. Explain the importance of Acetyl co-enzyme A.
2. Draw the molecular structure of a fat.
3. What is the bond called that is hydrolysed by lipase?
4. What is the difference between a saturated and unsaturated fatty acid?
5. What are the health implications of overconsumption of saturated fats?
6. What are fats hydrolysed to?
7. What happens to the glycerol?
8. What is the fate of the fatty acid molecules?
9. Draw the molecular structure of an amino acid. Label the basic and acidic ends.
10. Explain what the letter R in the formula means.
11. What is deamination?
12. Where does it take place?
13. What happens to the keto acids?
14. What happens to the ammonia?

Bacterial Structure

1. Construct a table to compare eukaryotes and prokaryotes.
2. Sketch a labelled diagram of a prokaryote, identify the structures that are always present and those that are only present in certain species.
3. What are the characteristics on which bacteria are classified?
4. What shapes are: cocci, bacilli and spirillum bacteria?
5. What is the main component of the bacterial cell wall?
6. What is the difference in cell wall composition between gram positive and gram negative bacteria?
7. Why is it important that a doctor knows if an infection is caused by a gram positive or gram negative bacterium?
8. Describe the steps of the gram stain procedure naming the stains used.
9. Explain why gram positive stain purple and gram negative stain red.
10. Draw and colour a gram negative coccus and a gram positive bacillus.

Culturing Bacteria

1. What is the difference between nutrient agar and nutrient broth?
2. Why do bacteria need a carbon source and what would be a suitable one?
3. Bacteria need a nitrogen source, why?
4. Name one inorganic and one organic nitrogen source that would be suitable.
5. Why would a bacterium need a sulphur source?
6. Name 3 molecules in a bacterium that contain phosphorus.
7. What would need to be added to the medium to grow a halophile?
8. What are the temperature ranges for thermophiles, mesophiles and psychrophiles?
9. Explain why bacteria are incubated at 25°C in sixth forms.
10. Why might a food hygiene microbiologist incubate agar plates at 37°C?
11. Give two reasons for sealing the plates with a sellotape cross.
12. Define the terms obligate aerobe, facultative anaerobe, obligate anaerobe.
13. Give two reasons for using aseptic technique.
14. Outline the ways in which you could ensure sterility and safety in the laboratory before and after culturing bacteria.
15. What are the steps in aseptic transfer of bacteria from culture to plate?

Counting techniques

1. Define viable and total counts.
2. Give the steps involved in preparing a 10-fold serial dilution.
3. Why is serial dilution necessary in a viable count?
4. Why would you count plate U and not plate T or V?

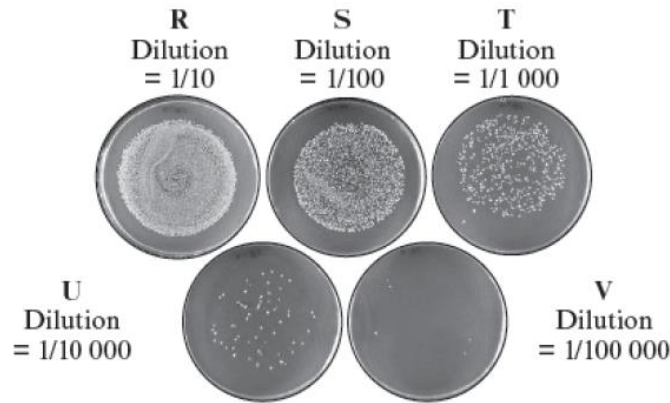

5. What are the assumptions made in this technique?
6. Why might the viable count technique lead to an underestimate of the number of bacteria?
7. At what temperature and for how long would you incubate the plates?
8. Plaques – clear points in a bacterial lawn – are formed when bacteriophage viruses destroy bacterial cells. What is the final dilution factor on the diagram? Calculate the number of viruses in 1 ml of the original sample using the plate where 345 plaques were counted

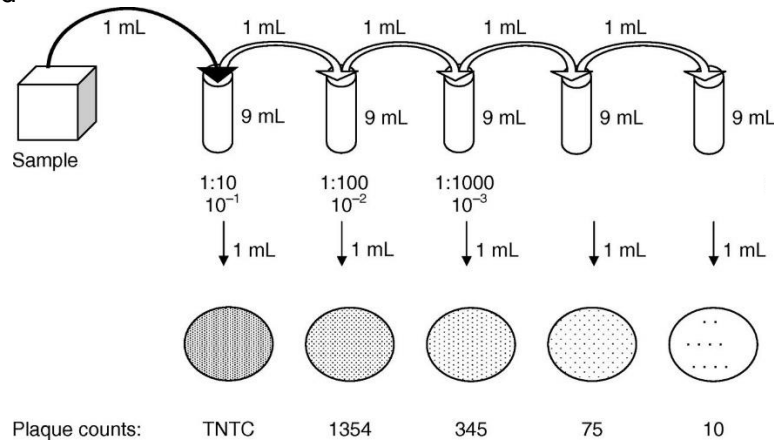

Population terms

- Distinguish between the following terms:
 - Habitat and niche
 - Biotic and abiotic
 - Population and community
 - Ecology and ecosystem
- List the four factors that affect how large a population is.
- Using the letters B, D, E and I write an equation for a stable population.
- What will happen to the size of the population if the birth rate exceeds death rate?
- Why is it not appropriate to use the term “birth” for populations of single-celled organisms like yeast, bacteria and paramecium? What term might be more appropriate?
- State a factor that could slow the population growth and one that could cause a population crash.
- This is a population growth curve for a bacterial broth culture. Describe what is happening at each of the phases.

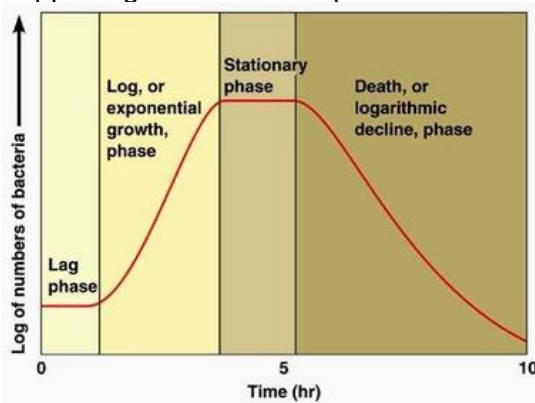

- Explain the shape of this curve:

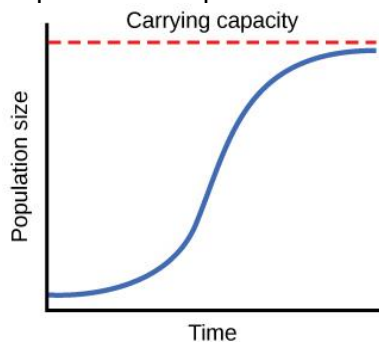

- What is meant by the term “carrying capacity”?

Density dependent and independent factors

1. Define density dependent.
2. Define density independent.
3. Name two density dependent factors and two density independent factors.

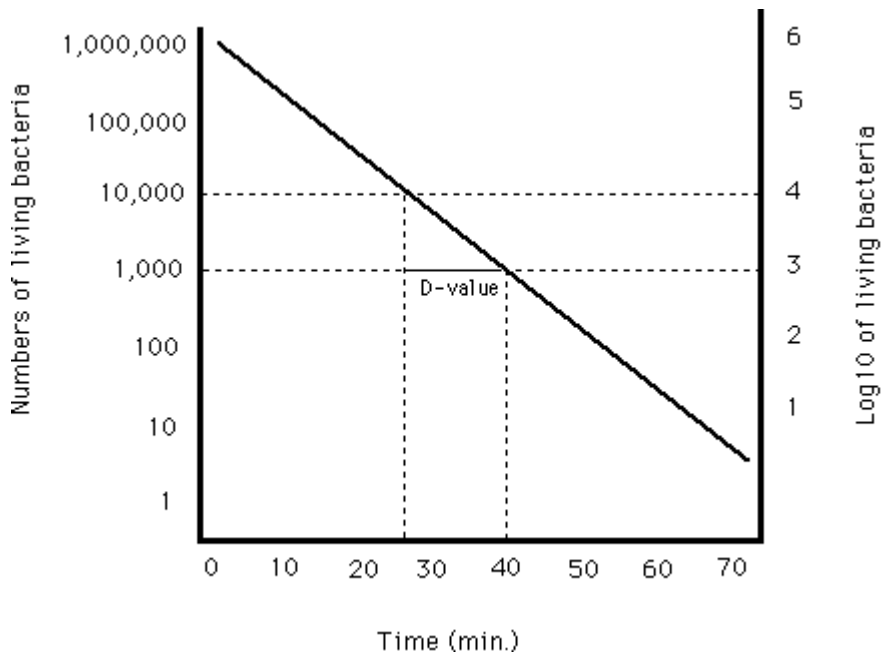

4. How many bacteria are there at 40 minutes?
5. The fall in living bacteria is because they have been heated. Is this a density dependent or independent factor?
6. What is the advantage of using log values when graphing populations of bacteria?

Sampling

1. Which type of sampling would you use to investigate an area with an ecological gradient?
2. Describe how you would carry out the investigation.
3. How could you present the data?
4. Which type of sampling would you use to investigate the effect of aspect on two sides of a hill?
5. Describe how you would carry out the investigation.
6. What calculation could you perform to assess the biodiversity in two areas?
7. What data would you need to collect to perform the calculation?
8. How could you improve the reliability of the data?

Energy Flow

1. What is the source of energy for most ecosystems?
2. Define GPP.
3. Define NPP
4. Write an equation using R for respiration to illustrate the relationship between NPP and GPP.
5. How is energy “lost” from each trophic level?
6. Calculate R_h on this diagram and the efficiencies of transfer from producers to herbivores and herbivores to carnivores in this food chain.

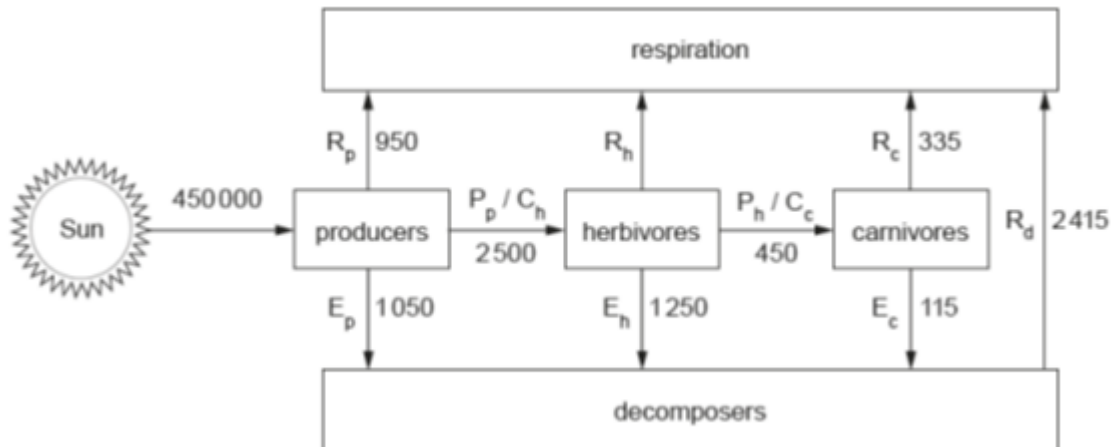

Succession

1. Define succession.
2. What is a seral stage?
3. Name the seral stages for a primary succession starting with bare rock.
4. What is the role of immigration in succession?
5. What is meant by facilitation in succession?
6. What happens to species diversity and the stability of ecosystems as a succession progresses?
7. What is the difference between primary and secondary succession?
8. What would be the independent variable in an investigation into succession?
9. How would you carry out the investigation?
10. What would you “measure”?

Nutrient Cycling

1. What is the role of detritivores in an ecosystem?
2. What modes of nutrition do they have?
3. What is the role of fungi and bacteria in nutrient cycling?
4. What modes of nutrition do they have?
5. What is the role of plants in nutrient cycling?
6. Why do plants need the following: nitrates, phosphates, sulphates and carbon dioxide?
7. How are mineral ions absorbed into root hairs?
8. How do mineral ions get transported throughout the plants?

Carbon Cycle

1. By what process is carbon dioxide removed from air by plants?
2. Give the names of two processes that return carbon dioxide to the atmosphere.
3. Explain two human activities that increase global carbon dioxide levels.
4. Explain why increasing carbon dioxide levels are increasing global temperatures.
5. Define carbon footprint.
6. Explain why humans should do the following to halt climate change:
 - a) Not fly
 - b) Not drive
 - c) Reduce electricity use
 - d) Be vegan
 - e) Buy locally produced groceries in season
7. What is the planetary boundary for carbon dioxide?
8. What is a planetary boundary?
9. Outline the effects of crossing the planetary boundary for carbon dioxide on land and in the oceans.

Nitrogen Cycle

1. What does “nitrogen is an inert gas” mean?
2. What is the process of nitrogen fixation?
3. Name the nitrogen-fixing bacteria that are free-living in soil.
4. How do they maintain the anaerobic conditions needed for nitrogen fixation?
5. Name the nitrogen-fixing bacteria that live in legume root nodules.
6. Why is this relationship described as symbiotic?
7. What is the function of leghaemoglobin?
8. What do fungi and bacteria convert amino acids and urea to in the process of decomposition?
9. Describe both steps in nitrification, naming the bacteria that do each step.
10. Is nitrification an aerobic or anaerobic process?
11. What is the impact of waterlogging on nitrification?
12. What is denitrification?
13. Under what conditions does denitrification take place?
14. What is the impact of waterlogging on nitrate levels of soil?
15. How would ploughing and draining fields increase nitrate levels in soil?

Eutrophication

1. Why are fertilisers applied to farmland?
2. What are the benefits and drawbacks of inorganic fertilisers?
3. What are the benefits and drawbacks of organic fertilisers?
4. What is leaching?
5. Describe the process of eutrophication.
6. Wildflowers grow on nutrient poor soils, how does the use of fertilisers impact species diversity?

Conservation

1. List the ways in which organisms are put at risk of extinction by human activity.
2. Define conservation.
3. List the measures that can be used to reduce the impact of human activity and conserve organisms.
4. Explain why conservation of gene pools is important.
5. What is meant by sustainable development?
6. Outline how sustainable development can maintain the world's forests.
7. List the ways in which fish stocks can be maintained at sustainable levels.
8. Explain the environmental impact of fish farming.

Homeostasis

1. What does homeostasis mean?
2. Name 3 factors that are kept at a constant in the human body.
3. What is the importance of homeostasis?
4. What is a set point?
5. What process corrects deviations from the set point?
6. What is the general term for a structure that detects a change in conditions?
7. What is the function of the co-ordinator?
8. Name two types of effector that can bring about the return to normal conditions.
9. What is positive feedback?
10. What are the two functions of the kidney?
11. What does osmoregulation mean?
12. What does excretion mean?
13. Where is urea made?
14. Outline the reactions involved in urea synthesis.

Kidney structure

1. What are the three main regions of the kidney?
2. Which blood vessel brings oxygenated blood to the kidneys?
3. State three ways in which the blood leaving the kidney differs from that entering.
4. What is the name of the tube connecting each kidney to the bladder?
5. What is the term for the knot of capillaries that is surrounded by Bowman's Capsule?
6. The cortex contains two sets of convoluted tubules, what are they called?
7. The medulla contains two sets of tubules, what are they called?
8. What is the name of the blood vessel that surrounds the Loop of Henle?
9. Name the blood vessels entering and leaving the glomerulus.
10. What is the term for the functional unit of the kidney?

Ultrafiltration

1. What cells surround the capillaries of the glomerulus?
2. What is the difference between the afferent and efferent arterioles?
3. How is high pressure generated in the capillaries of the glomerulus?
4. List the 3 layers of the filter involved in ultrafiltration.
5. What substances are filtered out of the blood?
6. What substances remain in the blood?
7. What is the term for the fluid inside the Bowman's capsule?

Selective Reabsorption

1. What does selective reabsorption mean?
2. Where does selective reabsorption take place?
3. List the adaptations of the proximal convoluted tubules for selective reabsorption.
4. By which mechanism is glucose reabsorbed into the blood from the filtrate?
5. Explain why there is a renal threshold for glucose absorption.
6. How are mineral ions reabsorbed into the blood from the filtrate?
7. By which transport mechanism is water reabsorbed from the filtrate?
8. Into which blood vessels are substances from the filtrate reabsorbed?
9. How does active transport of Na^+ out of the cells in the proximal convoluted tubule aid the reabsorption of glucose?
10. Describe the tonicity of the filtrate and the blood at the end of the proximal convoluted tubule.

Loop of Henle

1. What is the overall purpose of the Loop of Henle?
2. Which limb transports filtrate from the proximal convoluted tubule to the apex of the renal pyramid?
3. Which limb transports filtrate back to the cortex and the distal convoluted tubule?
4. Describe the permeability of the ascending limb to water.
5. Describe what happens to Na^+ and Cl^- in the ascending limb.
6. Describe the permeability of the descending limb to water.
7. Explain the process of water reabsorption into the vasa recta.
8. What happens to the water potential of the filtrate as it passes down the descending limb?
9. Explain why the water potential of the filtrate rises as it passes through the ascending limb.
10. What is the term that describes the action of the loop of Henle?

ADH

1. What does ADH stand for?
2. Which endocrine gland is ADH released from?
3. How does ADH get to the kidney from the endocrine gland?
4. What structures detect changes in blood water potential and where are they located?
5. What effect does ADH have on the cells of the collecting duct?
6. How is the change brought about?
7. What feature of the tissue fluid of the medulla allows water to be withdrawn from the collecting duct?
8. If ADH is present, what happens to the volume and concentration of the urine?
9. List 5 possible treatments for kidney failure.

Adaptations

1. Where do organisms that produce ammonia as a nitrogenous waste need to live?
2. Describe the toxicity of ammonia.
3. Which types of animals produce uric acid as their nitrogenous waste.
4. Give two advantages of uric acid as a nitrogenous waste.
5. What is the advantage to mammals of urea as a nitrogenous waste.
6. Why do mammals in arid environments have long loops of Henle?
7. Name a mammal with a long loop of Henle.
8. Name a mammal with a short loop of Henle.

Nervous System

1. Outline the pathway involved in responding to a stimulus.
2. What are the components of the central nervous system?
3. What is the nervous system that is not the CNS?
4. Sketch and label a cross-section of the spinal cord.
5. Explain the difference between white and grey matter.
6. Which type of nerves are present in the ventral root?
7. Where are the cell bodies of the nerves present in the ventral root?
8. Which type of nerves are present in the dorsal root?
9. Where are the cell bodies of the nerves present in the dorsal root?
10. Where are connector neurones found in the spinal cord?

Spinal reflexes

1. Define a simple reflex.
2. Describe the transmission of a nerve impulse along a three neurone reflex arc.
3. Name two types of effector.
4. Sketch a spinal cord cross section and add in the neurones, synapses and cell bodies of a three neurone reflex arc. Label the diagram.
5. What is the term for the arrangement of nerves in a simple organism like *Hydra*.
6. What is the difference in neurone types between a *Hydra* and a human?
7. What causes the limitations in response of a *Hydra*?
8. Describe a nerve net.
9. Draw and label a motor neurone.
10. Describe the functions of each of the features you have labelled.

Nerve impulse

1. Draw and label an oscilloscope trace of a nerve impulse, include the threshold.
2. Describe how the resting potential is maintained in a neurone.
3. Which type of ions are responsible for the negative charge inside of the neurone?
4. Describe how a stimulus results in an action potential being formed.
5. How is the resting potential restored?
6. What is hyperpolarisation?
7. What is the "all or nothing law"?
8. How does myelination of a neurone affect the transmission of an action potential along a neurone?
9. What is the speed of transmission in an unmyelinated axon and an myelinated axon?
10. How does temperature affect the speed of transmission?
11. Explain the effect of axon diameter on the speed of transmission.
12. Explain the role of local circuits in the transmission of a nerve impulse along an axon.

Synapse

1. What is a synapse?
2. Draw a labelled diagram of a synapse.
3. Describe how the arrival of an impulse at the synaptic knob results in the formation of an action potential in the post-synaptic neurone.
4. What three events prevent the merging of impulses at a synapse.
5. Explain how synapses result in a unidirectional transmission.
6. What is an agonist and antagonist chemical affecting the synapse?
7. How does an acetylcholinesterase inhibitor affect synaptic transmission?
8. How would a calcium ion transport blocker affect synaptic transmission?
9. If the uptake transporters are prevented from working, how will synaptic transmission be affected?
10. If post-synaptic receptors are blocked, how will synaptic transmission be affected?

Unit 4 Revision questions

Female reproductive system

1. Label the diagram with the name of the structure and the function of each.

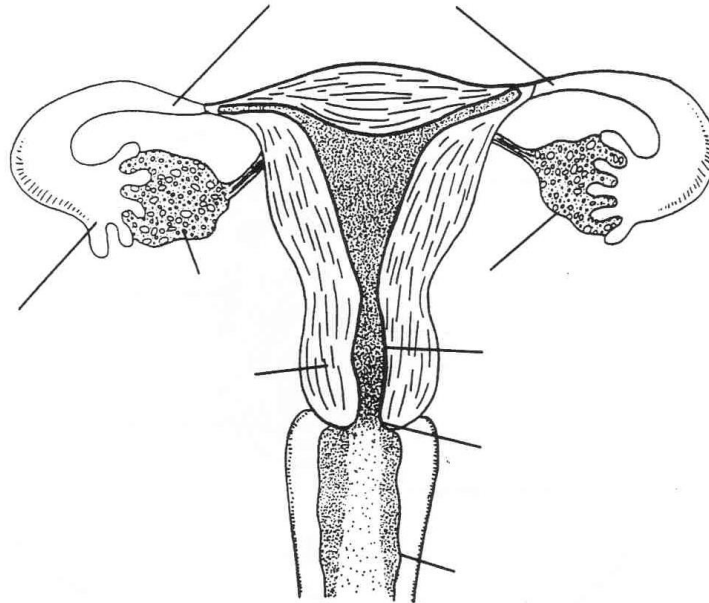

© 1983 by The Center for Applied Research in Education

2. Write out the sequence of events in oogenesis, include the timings and the phases of meiosis in which the cells are suspended.
3. Identify and label the structures on the diagram. Use the following words: **corpus luteum, corpus luteum, graffian follicle, primary follicle, secondary oocyte,**

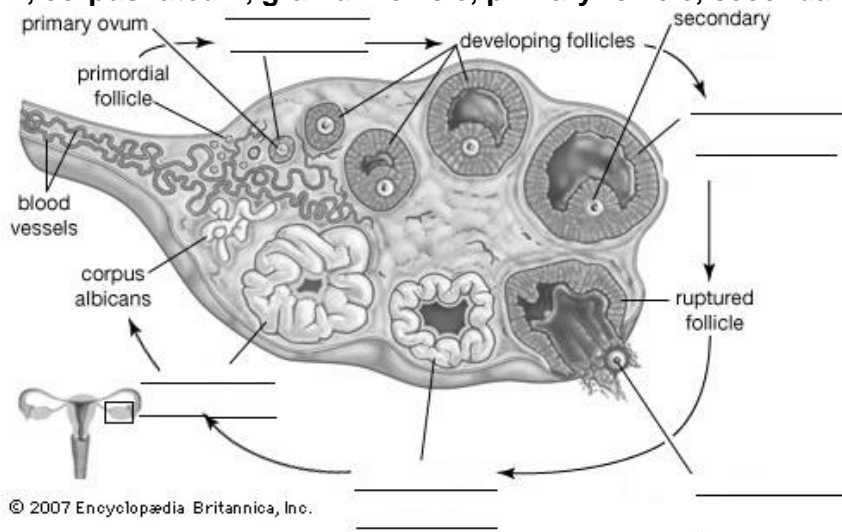

Male reproductive system

1. Label the diagram with the name of the structure and the function of each.

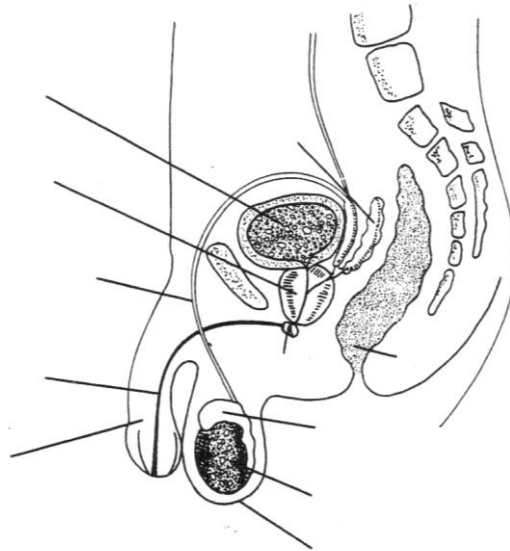

2. Write out the sequence of events in spermatogenesis, working from the germinal epithelium cells on the periphery of the seminiferous tubules to the spermatozoa in the lumen
3. What is the function of sertoli cells?
4. What is the function of leydig or interstitial cells?
5. What are the two significances of gametes?
6. Label this sperm cell and outline the functions of each part.

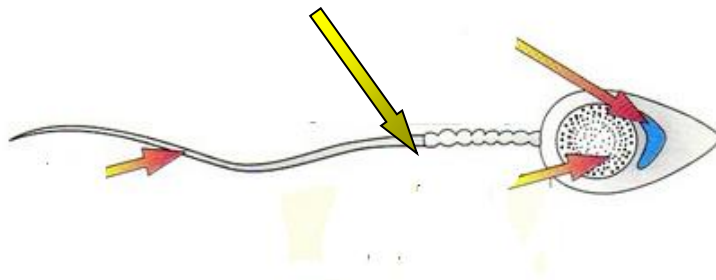

Fertilisation

1. What does capacitation involve?
2. What happens to the acrosome when the spermatozoa comes into contact with the zona pellucida?
3. Which two layers are digested through?
4. What happens when the spermatozoan membrane and oocyte membrane fuse?
5. What is the significance of the cortical reaction?
6. What does the entry of the sperm nucleus stimulate in the oocyte?
7. How is a zygote formed?
8. Label this diagram showing the events from fertilisation to implantation. Use the words: **blastocyst**, **cleavage**, **inner cell mass**, **trophoblast**, **zygote**

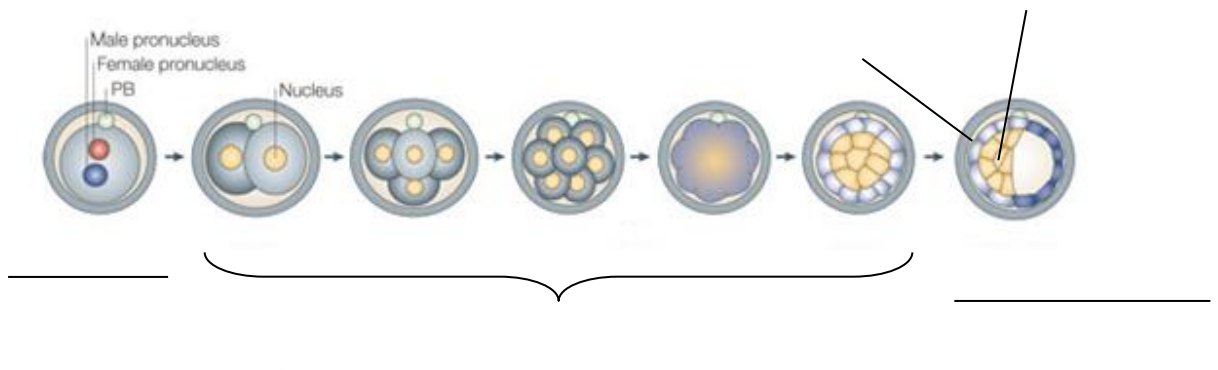

Copyright © 2005 Nature Publishing Group
Nature Reviews | Molecular Cell Biology

9. What does implantation mean?
10. Which hormone is released by the developing embryo?
11. What does the hormone do?
12. What is the application (use to humans) of this hormone?
13. Name one cause of female infertility and how it is diagnosed.

Female Reproductive Hormones

1. What are the two hormones released from the pituitary gland?
2. What is the function of FSH?
3. What hormone do the theca cells of the follicle produce as they develop?
4. What effect does oestrogen have on the uterus?
5. What effect does oestrogen have on FSH?
6. What is the term that describes the effect of oestrogen on FSH?
7. What causes ovulation?
8. What happens in the ovary after ovulation?
9. What hormone is produced by this structure?
10. What effect does progesterone have on the uterus?
11. What effect does progesterone have on the levels of FSH and LH?
12. Why is the timing of the release of hormones so important?
13. What happens the levels of progesterone when the corpus luteum degenerates?
14. What happens in the uterus when the levels of progesterone fall?
15. Explain the use of oestrogen and progesterone in the contraceptive pill.

Pregnancy

1. What hormone does the developing secrete during cleavage and after implantation?
2. What is the effect of this hormone on the ovary?
3. Which organ secretes progesterone from about 12 weeks onwards in a pregnancy?
4. What effect does progesterone have on the levels of FSH and LH?
5. What effect does progesterone have on the myometrium?
6. What effect does oestrogen have on the uterus?
7. What effect does oestrogen have on the mammary glands?
8. What is exchanged at the placenta and in which directions?
9. What are the two blood vessels in the umbilical cord?
10. Which of the two blood vessels delivers blood to the placenta from the foetus?
11. How does the composition of blood in the umbilical artery differ from that in the umbilical vein?
12. What is the importance of the chorionic villi in the placenta?
13. How does countercurrent flow between the villi and intervillous spaces aid diffusion?
14. Why is it important that there is a barrier between maternal and foetal blood?
15. Why is it important that the pressure of the blood in the mother is higher than that of the foetus?
16. What is the significance of the breakdown of the maternal placental capillaries to form intervillous spaces?
17. What structure secretes amniotic fluid?
18. What is the function of amniotic fluid?
19. What happens to the levels of oestrogen and progesterone before birth?
20. How does this facilitate the birthing process?
21. What is the function of oxytocin in childbirth?
22. What type of feedback is this?
23. What is the function of oxytocin following birth?
24. What is the function of prolactin?

Plant Reproduction

1. Which parts of the flower make up the carpel?
2. Which parts of the flower make up the stamen?
3. Whereabouts in the flower are the male gametes/ pollen made?
4. Whereabouts in the flower are the female gametes made?
5. What structures do insect pollinated plants have that wind pollinated do not?
6. List three features of insect pollinated plants.
7. Describe the development of the pollen grain.
8. How are meiosis and mitosis involved in gamete production in the anther?
9. What is the function of the exine?
10. Describe how a mature embryo sac develops.
11. How are meiosis and mitosis involved in the production of the embryo sac in the ovule?
12. Draw a diagram of a mature embryo sac, label the integuments, micropyle, antipodal nuclei, polar nuclei, egg cell, and synergids.
13. Distinguish between the terms cross pollination and self pollination
14. What are the sources of variation in the offspring of self-pollinated plants?
15. What are the advantages of cross pollination?
16. Describe a structural adaptation to promote cross-pollination.
17. What are the names of the two nuclei in a mature pollen grain?
18. Describe pollen tube growth.
19. Which type of cell division produces two sperm nuclei from the generative nucleus?
20. Which nuclei fuse at fertilisation?
21. Draw a diagram to show a fertilised embryo sac, label the parts that will become the testa, micropyle, endosperm, zygote and fruit.

Germination

1. What is the significance of a seed in the life-cycle of a plant?
2. Explain what happens during germination of a seed.
3. Describe the difference between a monocotyledonous and dicotyledonous plant.
4. What is the difference between an endospermic and cotyledonous seed?
5. Which hormone does the embryo release at germination?
6. What does this hormone stimulate?
7. What is the role of the aleurone layer?
8. Sketch a graph of gibberellin and amylase production during germination.
9. What does amylase do?
10. How can you test for presence or absence of starch?
11. Describe the experiment that assesses amylase production in germinating seeds.
12. Identify the dependent variable.
13. Identify two variables that should be controlled.
14. Explain how the removal of the embryo from the seed prior to the experiment could affect the results.
15. Describe germination in the barley fruit.
16. Why is barley a fruit?

Inheritance

1. Define:
 - a) Allele
 - b) Dominant
 - c) Recessive
 - d) Homozygous
 - e) Heterozygous
 - f) Homologous chromosomes
 - g) Co-dominant
2. State Mendel's first and second laws.
3. What does pure-breeding mean?
4. In monohybrid inheritance what are the genotypes of the parent that lead to a 3:1 ratio of dominant to recessive phenotypes?
5. In monohybrid inheritance what are the genotypes of the parents that lead to a 1:1 ratio of dominant to recessive phenotypes?
6. Describe a test cross and the expected results.
7. For a monohybrid cross, how many letters should there be in the genotype and the gametes?
8. Describe how a 1: 2: 1 phenotype ratio arises
9. Give an example of this type of inheritance in humans
10. Give the genotypes of the individuals that would when mated give a 9:3:3:1 ratio of phenotypes
11. Set out a cross between individuals with the genotypes: HhTt and hhtt.
12. What does the term linkage mean?
13. Which sex chromosome determines maleness?
14. Give all the possible genotypes of a female without colour blindness.
15. Give the genotypes of a male with colour blindness and a male without colour blindness
16. Explain why sex-linked characteristics are more frequently displayed in the phenotype than in females

χ^2 test

1. Write a null hypothesis for a χ^2 test to assess whether the results of a cross where 24 individuals have the dominant phenotype and 16 have the recessive phenotype conform to the 3:1 ratio expected.
2. Write out the table headings for a χ^2 test.
3. Which probability level is used for χ^2 ? Explain why.
4. How would you work out the degrees of freedom to use?
5. What does the critical value mean?
6. What conclusion can you reach if the critical value is bigger than the calculated value of χ^2 ?
7. Carry out a χ^2 test to test if the results of a cross where 35 individuals have the dominant phenotype and 29 have the recessive phenotype conform to the expected ratio of 1:1.
 - a) Write a null hypothesis
 - b) Carry out the calculation
 - c) Work out the critical value
 - d) Write a statement to explain why you are rejecting or accepting your null hypothesis

Key Questions Mutation

1. Define a mutation.
2. Distinguish between somatic and germ line mutations
3. What are agents that raise mutation rate called?
4. What is a carcinogen?
5. What is a proto-oncogene?
6. What are features of organisms have naturally high mutation rates?
7. During which phases of meiosis are mutations most likely?
8. Explain the effect of a substitution mutation on the protein made.
9. Why might a substitution mutation not have an effect on the protein made?
10. How is sickle-cell anaemia inherited?
11. What is the benefit of sickle-cell-trait?
12. What is the cause of sickle-cell anaemia?
13. What kind of mutations cause a frame-shift, explain what a frame-shift is.
14. What do the terms trisomy and monosomy mean?
15. Explain the cause of trisomy.
16. What syndrome is caused by trisomy of chromosome 21?
17. What is epigenetics?
18. What effect does methylation of cytosine groups on DNA have?
19. What effect does loose coiling of DNA around histones have?
20. What do different epigenetic modifications result in?

Variation

1. What are the two main causes of variation between individuals?
2. What is a genotype?
3. What is a phenotype?
4. What is phenotype dependent on?
5. What two events lead to genetic differences in daughter cells produced by meiosis and in which phases do these occur?
6. What is the genetic basis of continuous variation?
7. What is the genetic basis of discontinuous variation?
8. Sketch graphs to show continuous and discontinuous variation.
9. What is non-heritable variation?
10. Explain one example of non-heritable variation in humans.
11. Which type of variation is most influenced by non-heritable factors?
12. What are the sources of variation in sexual reproduction?
13. What can cause variation to occur initially?
14. What do twin studies show?
15. What does standard deviation show?
16. What type of data is suitable for a t-test?
17. What is a t-test used to assess?
18. Describe how the degrees of freedom are established?
19. Which level of probability is used?
20. What conclusion would you arrive at if the t value was greater than the critical value?

Evolution

1. Define:
 - a) Species
 - b) Community
 - c) Population
 - d) Intraspecific competition
 - e) Interspecific competition
 - f) Gene pool
 - g) Selection pressure
 - h) Selective advantage
 - i) Genetic drift
 - j) Founder effect
2. Outline the steps in natural selection.
3. Give two examples of geographical barriers that could lead to allopatric speciation.
4. Describe allopatric speciation.
5. In the Galapagos archipelago the same species of mockingbird is found on the islands that are closer together, explain this.
6. Give two examples of barriers to gene flow that could lead to sympatric speciation.
7. How would you recognise that sympatric speciation is responsible for different species from a distribution map?

Hardy-Weinberg Equilibrium

1. What is the Hardy-Weinberg Equilibrium?
2. What conditions apply for the Hardy-Weinberg Equilibrium?
3. Write the two equations defining each of the terms in the equations.
4. In humans the ability to taste the chemical PTC is inherited as a simple dominant characteristic. Suppose you found out that 360 out of 1000 college students could not taste the chemical.
 - a) State the frequency of the gene for tasting PTC
 - b) Determine how many students in this population are heterozygous.
5. It is known that 64% of a large population exhibit the recessive trait of a characteristic controlled by 2 alleles, one of which is dominant over the other.
 - a. Determine the frequency of the recessive allele in this population.
 - b. Determine the % of the population that is heterozygous for this trait.
 - c. Determine the % of the population that exhibits the dominant trait of this characteristic.
 - d. Determine the % of the population that is homozygous for the dominant trait.
 - e. Determine the % of the population that has one or more recessive alleles.

Human Genome Project:

1. What are the aims of the human genome project?
2. What has it achieved so far?
3. What are the benefits of genetic screening?
4. What are the ethical issues arising from genetic screening?
5. What is eugenics?
6. Give 3 ethical implications that the human genome project raises.
7. What is genetic counselling?
8. Who do you think should have access to your genetic information? Explain your choices.
9. What is the 100K project?
10. What possible benefits are there to it?
11. Why has the genome of the chimpanzee been sequenced?
12. What is the relationship between the *Anopheles* mosquito and *Plasmodium* parasite?
13. What issues have arisen through insecticide use to control mosquito populations and drug use to treat and prevent malaria?
14. Why have *Anopheles* and *Plasmodium* had their genomes sequenced?

Genetic Fingerprinting

1. What is special about an individual's genetic profile or genetic fingerprint?
2. What are exons?
3. What is variable between individuals?
4. What are restriction enzymes used for in genetic fingerprinting?
5. Describe gel electrophoresis.
6. On what basis are the fragments of DNA separated?
7. How are the characteristic banded patterns of a DNA fingerprint produced?
8. What is the purpose of the DNA ladder?
9. Why are log values used to work out the length of DNA fragments?
10. Name two types of cell that would be used to produce genetic fingerprints in a forensic context.
11. What is the technique by which small samples of DNA, (eg from a blood droplet/ saliva smear) can be amplified to produce enough DNA for a fingerprint?
12. Outline the steps involved in PCR.
13. What happens when the DNA is heated to 95°C?
14. What are primers?
15. What does DNA polymerase do?
16. Why is it important to cool the DNA to 55°C before adding the polymerase enzyme?
17. Why is it important to avoid contamination from other cells when using this technique?
18. When using genetic fingerprinting forensically scientists look for a perfect match; what would they look for in determining paternity (use a diagram if this will help).

Recombinant DNA Technology

1. Define recombinant DNA.
2. What is a vector?
3. Outline the steps in making a recombinant vector – such as a plasmid.
4. Outline the roles of the following enzymes in genetic engineering:
 - a) Restriction endonuclease
 - b) DNA ligase
 - c) Reverse transcriptase
 - d) DNA polymerase
5. Distinguish between the terms blunt and sticky ends.
6. Explain the usefulness of sticky ends.
7. Why is it important to utilise the same restriction endonuclease to make the sticky ends for vector and gene?
8. What are introns?
9. What are the advantages of using reverse transcriptase to isolate genes?
10. Which type of genes are used as genetic markers to enable identification of altered bacteria?
11. Give two applications of using recombinant DNA technology.
12. Outline the advantages, problems and hazards associated with recombinant DNA technology.

Gene Therapy

1. What is the aim of gene therapy?
2. Distinguish between germ line and somatic cell therapy.
3. Give three risks associated with gene therapy.
4. What are the difficulties associated with gene therapy?
5. What are the advantages and disadvantages arising from using viruses to vector functioning genes into humans?
6. Why must somatic gene therapy treatment be repeated?
7. Why might someone receiving somatic gene therapy want to attend genetic counselling before becoming a parent?
8. What is a “saviour sibling”?
9. What are the ethical issues associated with “saviour siblings”?
10. What are stem cells?
11. What is tissue culture?
12. What feature do stem cells have that make them suitable for tissue culture?
13. What are the ethical issues associated with obtaining stem cells?
14. What are the disadvantages of using stem cells?

Option A Revision Questions

Terminology

1. What does pathogenic mean?
2. What does infectious mean?
3. What word describes a person who is asymptomatic but can pass a disease on to someone else?
4. What is a disease reservoir?
5. What term describes a disease which is always present at low levels in an area?
6. When there is a rapid spread of a disease causing an increase in cases, how is this described?
7. What is a pandemic?
8. How do vaccines protect against disease?
9. What are antibiotics?
10. What is a vector?
11. What is a toxin?
12. What does the term “antigenic types” mean?

Disease

1. What is the causative organism of cholera?
2. What does endemic mean?
3. What do the toxins the cholera bacterium releases cause?
4. What does “humans act as reservoirs or carriers” mean?
5. How is cholera contracted?
6. List the ways in which cholera outbreaks can be prevented.
7. What is the treatment for cholera?
8. How is tuberculosis transmitted?
9. Which tissues does tuberculosis mainly affect?
10. What are the symptoms of tuberculosis?
11. How is tuberculosis prevented?
12. How is tuberculosis treated?

Viral diseases

1. What is the cause of influenza?
2. What is an antigen?
3. Influenza has “many antigenic types”, what does this mean?
4. Which cells does influenza infect?
5. What are the symptoms of influenza?
6. How is influenza spread?
7. How can the spread of influenza be prevented?
8. Explain why antibiotics are ineffective against influenza.
9. Why in the influenza vaccine not always effective?
10. What is the causative organism of smallpox.
11. What is the fatality rate of smallpox?
12. Explain how the immunisation program was able to cause the extinction of smallpox.
13. Describe the lytic cycle of viruses.
14. List the ways in which viruses cause pathogenic effects.



Malaria

1. What is the causative organism of malaria?
2. What kingdom does this organism belong to?
3. What is the mode of nutrition of the organism?
4. Which cells does the organism initially invade?
5. In which cells does the organism multiply?
6. How do the severe bouts of fever come about?
7. What is a vector?
8. What is the vector for malaria?
9. List the ways in which the vector can be prevented from biting hosts.
10. List the ways in which the larvae of the vector be killed.
11. How can the adult populations of vectors be controlled?
12. Explain why developing a vaccine has been difficult.
13. When is the causative organism affected by drugs.
14. What is "resistance" to drugs?

Antibiotics

1. What are antibiotics used for?
2. Distinguish between the terms bactericidal and bacteriostatic.
3. Describe the structure of a bacterial cell wall.
4. What does the bacterial cell wall protect bacteria from?
5. Describe the difference between gram negative and gram positive cell walls.
6. What is the advantage of a gram negative cell wall structure?
7. Describe how penicillin acts to kill bacteria.
8. Which type of bacteria is penicillin effective against?
9. Describe the mode of action of tetracycline.
10. Why do antibiotics not affect viruses?
11. What is antibiotic resistance?
12. Describe how antibiotic resistance develops.

Non-specific immunity

1. How does the skin protect from infection?
2. Why is vitamin C necessary?
3. How do microbes living on the skin (skin flora) help to protect from infection?
4. What is the purpose of blood clotting?
5. What is the purpose of inflammation?
6. Describe the process of phagocytosis.
7. What is the function of mucus in the airways?
8. What is the function of the ciliated cells in airways.
9. Where is lysozyme found and what does it do?
10. What is the protective function of hydrochloric acid in the stomach?

Specific Immunity

1. Which two types of cell are involved in specific immunity.
2. Where do B cells originate and mature?
3. Which type of specific immunity involves B cells?
4. How are B lymphocytes activated?
5. Which types of cell are produced following activation?
6. What is the function of memory cells?
7. Describe the structure of an antibody?
8. How do antibodies act?
9. What type of cell is involved in the cell-mediated response?
10. Where do T cells originate and mature?
11. What types of T cells are produced after activation and state the function of each type.
12. Which chemicals are involved in stimulating B cells to release antibody?
13. Describe the primary immune response.
14. Describe the secondary immune response.

Types of immunity

1. Distinguish between active and passive immunity.
2. Distinguish between natural and artificial immunity.
3. Which type of immunity is brought about by a vaccine?
4. What type of immunity is brought about by injection of antibodies?
5. What are the advantages of antibody injection?
6. What features of the antigens of pathogens cause difficulties with vaccination programmes?
7. What are the features of a successful vaccine?
8. List the ethical issues involved in vaccination programmes.

Option B Revision Questions

Cartilage

1. What are the cells in cartilage tissue called?
2. What is the substance called that the cells are embedded in?
3. How do nutrients and oxygen reach the cells?
4. Describe the structure of hyaline cartilage – use a diagram if it helps.
5. Where is hyaline cartilage found?
6. Describe the structure of yellow elastic cartilage.
7. Where is yellow elastic cartilage found?
8. Describe the structure of white fibrous cartilage.
9. What property does white fibrous cartilage have?
10. Where is white fibrous cartilage found?

Bone

1. What are the two main components of bone?
2. What are the relative proportions of the two components?
3. What is the function of each component?
4. What are the two types of osteocyte found in bone?
5. What are the functions of the two types of osteocyte?
6. Draw a labelled diagram of an Haversian system.
7. What is the function of the Haversian canal?
8. Describe how oxygen and nutrients reach the osteocytes through Volkmann's canals and canaliculi.

Bone disorders

1. Name a vitamin and a mineral that are necessary for healthy bone development.
2. What is the condition in children caused by vitamin D deficiency.
3. Why is vitamin D necessary in the body.
4. Name a dietary source and one other source of vitamin D.
5. What causes osteomalacia?
6. What is the cause of brittle bone disease?
7. What is the medical term for brittle bone disease?
8. What are the two treatments for brittle bone disease?

Muscle structure

1. What is skeletal muscle made up of?
2. What is the appearance of a muscle fibre?
3. What is each muscle fibre made up of?
4. Draw a diagram of a muscle sarcomere and label: the Z line, thin actin, thick myosin, A band, I band, H zone and M line.
5. What determines the length of the A band?
6. Which type of filament is found in the I band?
7. Which type of filament is found in the H zone?
8. How does the arrangement of actin and myosin lead to the striated appearance of a muscle fibre?

The Sliding Filament Theory

1. Describe the structure of the thick myosin filaments.
2. Which three proteins make up actin filaments?
3. Describe the arrangements of the proteins in the actin filaments.
4. Describe what happens to the length of the A band, H zone and I band when striated muscle contracts.
5. What causes Ca^{2+} to be released from the sarcoplasmic reticulum?
6. What is the consequence of the release of Ca^{2+} .
7. Describe how the myosin binding sites on actin are exposed.
8. Which part of the myosin forms cross-bridges with the binding sites on actin?
9. Describe the power stroke of muscle contraction.
10. What is ATP used for during muscle contraction?

Fast and slow twitch muscle fibres

1. Which type of muscle fibres are advantageous to a marathon runner?
2. Which type of respiration do slow twitch muscles mainly carry out?
3. Which cell organelle allows this type of respiration to dominate?
4. Describe the blood supply of slow twitch muscle fibres.
5. Which respiratory pigment is found in slow twitch muscle fibres?
6. Describe 3 other features of slow twitch muscle fibres.
7. Which type of respiration do fast twitch muscle fibres carry out?
8. Why are fast twitch muscle fibres an asset to a sprinter?

Energy sources

1. When is creatine phosphate made?
2. What is the purpose of creatine phosphate as oxygen levels fall?
3. When creatine phosphate runs out which reactions of respiration supply ATP?
4. What effect does lactic acid build-up have on muscles?
5. What is the main carbohydrate store in muscle?
6. What is the purpose of carbohydrate loading?
7. What is used in preference to fat as an energy source?

The skeleton

1. List four functions of the skeleton.
2. List the bones in the axial skeleton.
3. List the bones in the appendicular skeleton.
4. What are the five types of vertebrae?
5. What is the function of the atlas and axis vertebrae?
6. What is the function of the vertebral body?
7. What is the function of vertebral processes?
8. What do facets on vertebrae do?
9. Which type of vertebrae have the most robust vertebral bodies?
10. Why do thoracic vertebrae have more facets than cervical vertebrae?
11. Which type of vertebrae are fused into the sacrum?
12. Which type of vertebrae are fused to form the "tailbone".

Fractures and Postural Deformities

1. List the causes of fractures.
2. What is the difference between a displaced and non-displaced fracture?
3. What is the difference between a simple and compound fracture?
4. What is a comminuted fracture?
5. What does the treatment of a fracture involve?
6. What are the roles of osteoblasts and osteoclasts in healing fractures?
7. What are the advantages of pinning or plating bones following fracture?
8. What is the cause of scoliosis?
9. How are minor and severe scoliosis treated?
10. What are flat feet and how are they treated?
11. What is the cause of knock knees?

Types of Joint

1. What range of movement does a gliding joint provide, give one example.
2. What type of joint provides movement in one plane only?
3. Give two examples of a ball and socket joint.
4. Where are immovable/fused joints found?
5. Draw a labelled diagram of a synovial joint.
6. What is the function of cartilage in a synovial joint?
7. What fluid does the synovial membrane secrete?
8. What is the function of ligaments?
9. Explain what is meant by antagonistic muscles.
10. Give an example of antagonistic action of named muscles.

Arthritis

1. Name two types of arthritis.
2. What effect does “wear and tear” have in a joint in osteoarthritis?
3. What type of activities increase the risk of developing osteoarthritis?
4. What treatments are available to someone suffering from osteoarthritis?
5. List the advantages of surgical replacement of joints in treating osteoarthritis.
6. List the disadvantages of surgical replacements of joints.
7. What type of disease is rheumatoid arthritis?
8. What are the risk factors for developing rheumatoid arthritis?
9. List the treatments for rheumatoid arthritis.

Levers

1. How many orders of lever are there?
2. 1,2,3 FLE is a way of remembering lever orders. What do the letters F, L and E stand for?
3. 1,2,3 FLE states the which relative position of the components?
4. What body structure provides the effort in a joint lever?
5. Give an example of each type of lever in the body.

Option C Revision Questions

Structure and function of the brain

1. Draw and label a diagram of the brain to show the positions of: the cerebrum, hypothalamus, hippocampus, cerebellum and medulla oblongata.
2. What are the three membranes called that surround the brain?
3. What is inflammation of these membranes called?
4. What are the four ventricles filled with?
5. What is the function of cerebrospinal fluid?
6. What does the hindbrain consist of?
7. List the functions of the medulla oblongata.
8. Which part of the brain is involved with maintenance of posture and co-ordination of voluntary muscular activity?
9. What does the midbrain contain?
10. What are the main regions of the forebrain?
11. What does the cerebrum control?
12. Which part of the brain links to the endocrine system via the pituitary gland?
13. What does the hypothalamus control?
14. What is the thalamus?
15. Which parts of the brain make up the limbic system?
16. What is the limbic system involved with?
17. What does the hippocampus do?

Autonomic Nervous System

1. What processes does the autonomic nervous system control?
2. What are the two branches of the autonomic nervous system called?
3. When the sympathetic system is activated what happens to ventilation and heart rates?
4. Which neurotransmitter is associated with the sympathetic system?
5. What effect does the parasympathetic system have on the body?
6. Which neurotransmitter is associated with the parasympathetic system?
7. Describe the relationship between the sympathetic and parasympathetic systems.
8. Which part of the brain acts as a link between the nervous and endocrine systems.

Cortex

1. What connects the two hemispheres of the cerebrum?
2. What is the significance of the folding of the cerebral cortex?
3. What is the cerebral cortex responsible for?
4. What are the outer and inner areas composed of?
5. List the lobes of the cerebral cortex.
6. What does the frontal lobe control?
7. Which lobe is involved in language, learning and memory?
8. Which lobe is involved in somatosensory functions and taste?
9. Which lobe is involved with vision?
10. What do the sensory areas of the cortex do?
11. What do the sensory areas of the cortex do?
12. Why will stimulation of the right hemisphere cause actions in the left side of the body?
13. What do the association areas do?
14. What causes the tongue, lips and fingertips to be highly sensitive?
15. What does the sensory homunculus represent?
16. What does the motor homunculus represent?

Speech and language

1. What are the names of the two main areas involved in speech and language?
2. Where are these areas located?
3. Where are the sensory areas involved located?
4. What is Wernicke's area responsible for?
5. What is Broca's area responsible for?
6. Name the bundle of nerve fibres that links the two areas.

Brain Imaging

1. What does EEG stand for?
2. What does EEG involve?
3. What type of images does a CT scan produce?
4. What is an advantage of a MRI scan over a CT scan?
5. What is fMRI a technique for doing?
6. How does a PET scan work?
7. Which two imaging techniques use radiation?
8. Which two imaging techniques will show structures only?

Brain Development

1. What does neuroplasticity mean?
2. When does neuroplasticity occur?
3. What is developmental plasticity?
4. What is synaptic pruning?
5. What is the significance of synaptic pruning?
6. What must happen during the critical period for neural connections to develop properly?
7. When do babies begin to produce speech sounds?

8. What is the evidence that shows speech and language development must occur in early life?

Epigenetics

1. What is epigenetics?
2. List the effects on mental health of those who have suffered childhood abuse.
3. Outline one hypothesis that explains this effect.
4. Describe the levels of cortisol in adults that have had traumatic childhood experiences.
5. Where is cortisol released from?
6. What is cortisol release a response to?
7. Which part of the brain controls cortisol release?
8. What area of the brain releases ADH and corticotrophin-releasing hormone?
9. Which part of the brain is stimulated by ADH and corticotrophin-releasing hormone?
10. What receptors on the hippocampus does cortisol in circulation bind to?
11. How does negative feedback prevent humans becoming overstressed?
12. What hormone has higher levels in adults who had suffered childhood abuse?

Behaviour

1. List three types of innate behaviour.
2. Distinguish between taxis and kinesis.
3. Define a reflex action.
4. Define learning.
5. What term describes learning to ignore a stimulus that provides neither a reward or punishment?
6. What is imprinting?
7. Distinguish between operant and classical conditioning.
8. Distinguish between latent and insight learning.
9. What is imitation learning?
10. How do cultural differences arise in populations that engage in imitation learning?

Social Behaviour

1. What do social interactions involve?
2. What does social behaviour rely on?
3. What is a "sign stimulus"?
4. What does the level of response depend on?
5. What is a fixed action pattern?
6. Give one advantage of living in a social group.
7. Give one disadvantage of living in a social group.

Social Insects

1. Give three types of social insects.
2. What is a "caste"?
3. What is the name of the only fertile female in a honeybee colony?
4. Which other caste of honeybees are fertile?
5. What is the advantage of division of labour within a colony?
6. In what ways do honeybees communicate with each other?

7. What information is communicated by a “round dance”?
8. What information is communicated by a “waggle dance”?

Dominance Hierarchies and other behaviours

1. What is a dominance hierarchy?
2. What is meant by “most dominance hierarchies are linear”?
3. What condition needs to be met in order for a species to have a dominance hierarchy?
4. What is the advantage of a dominance hierarchy?
5. What maintains dominance hierarchies?
6. What is a courtship behaviour?
7. What is territoriality?
8. What is the advantage of having courtship behaviours?
9. What is sexual dimorphism?
10. Distinguish between sexual and natural selection.
11. Outline the different theories behind the driving force of sexual selection.